

# Transact 2+ User's Guide

Copyright© Telequip Corporation, 2003  
Part # 350-006  
Rev. 0505

**Telequip Corporation**  
5 Industrial Way  
Salem, NH 03079

*Telephone:* 603-685-6999  
*Fax:* 603-685-6997

[www.telequip.com](http://www.telequip.com)

---

## **Limitation of Liabilities**

Telequip has taken reasonable care in the preparation of this manual, and will not be liable for damages arising out of the use of this product or its documentation.

## **Software and Hardware Disclaimers**

Proper operation and functionality of the Transact 2+ Coin Dispenser (dual-voltage model) depends upon specific programming of the point of sale (POS) device or Teller system software. Check with your software provider to ensure that the proper communications programming is in place to interface with the Transact 2+ Coin Dispenser.

Certain add-on hardware devices, such as serial expansion boards, may not pass the correct signals to the Transact 2+, thereby causing unpredictable results.

## **FCC Statement**

Changes or modifications to this unit not expressly approved by the party responsible for compliance could void the user's authority to operate the equipment.

This equipment has been tested and found to comply with the limits for a Class A digital device, pursuant to Part 15 of the FCC Rules. These limits are designed to provide reasonable protection against harmful interference when the equipment is operated in a commercial environment. This equipment generates, uses, and can radiate radio frequency energy and, if not installed and used in accordance with the instruction manual, may cause harmful interference to radio communications. Operation of this equipment in a residential area is likely to cause harmful interference in which case the user will be required to correct the interference at their own expense.

## **Trademarks**

Product names used in this guide may be trademarks or registered trademarks of their respective companies.

# Contents

<b>Limitation of Liabilities</b> .....	<b>i</b>
<b>Software and Hardware Disclaimers</b> .....	<b>i</b>
<b>FCC Statement</b> .....	<b>i</b>
<b>Trademarks</b> .....	<b>i</b>
<b>Safety Warnings and Cautions</b> .....	<b>3</b>
Safety Icons.....	3
Audience.....	3
Hazardous Voltages .....	4
Heavy Objects .....	4
<b>Preface</b> .....	<b>5</b>
<b>General Information</b> .....	<b>5</b>
Introduction .....	5
International features.....	6
Related Documentation .....	6
Warranty Coverage and Service.....	6
Technical Support.....	7
<b>Factory Service</b> .....	<b>7</b>
How to Obtain Service .....	7
Packing the Coin Dispenser for Shipping .....	8
Shipping Charges.....	8
Repair Charges.....	8
<b>Getting to Know the Transact 2+</b> .....	<b>9</b>
<b>Installation</b> .....	<b>11</b>
Before You Begin .....	11
Factory Settings.....	12
Installing the Coin Dispenser.....	12
Changing the Coin Cup.....	13
<b>Employee Training</b> .....	<b>14</b>
<b>Coin Dispenser Features</b> .....	<b>15</b>
Dispensing Coins.....	15
Even Depletion and Minimum Dispense .....	15
Coin Capacity.....	15
Low Coin Alarm.....	16
Lock Assembly.....	16
Power Cable .....	16
Communications Cable .....	17

<b>Operation .....</b>	<b>17</b>
Filling the Coin Canister .....	17
Reading the Calibration Strips .....	18
Additional Canisters .....	18
Cash Management Procedures .....	19
<b>Maintenance .....</b>	<b>20</b>
<b>Troubleshooting .....</b>	<b>21</b>
<b>Parts List .....</b>	<b>23</b>
<b>Specifications .....</b>	<b>24</b>
<b>Troubleshoot Flowchart .....</b>	<b>25</b>
<b>Attaching the Optional Mount Bracket #340-460 .....</b>	<b>26</b>
<b>Surface Mounting Procedure .....</b>	<b>27</b>
<b>Through Counter Mounting Procedure .....</b>	<b>28</b>
<b>Single Bolt Mounting Procedure .....</b>	<b>29</b>
<b>Mounting Procedure .....</b>	<b>30</b>
<b>Mounting Spacer Procedure .....</b>	<b>31</b>
<b>Canister Loading Solution Instructions .....</b>	<b>32</b>
<b>Telequip Transact 2+ Mounting Hole Template</b>	
<b>EZ Fill Procedure .....</b>	<b>Quick Reference Card</b>

# Safety Warnings and Cautions

The Transact 2+ Coin Dispenser is a safe product. All the necessary precautions have been taken to ensure that normal operations and maintenance procedures are safe.

Telequip Corporation will not be held liable for damages and/or personal injuries brought on by incorrect operation and maintenance practices.

## Safety Icons



***Electrical Shock Hazards*** – indicates potentially lethal voltages are present.



***Stop!*** – identifies important information requiring special attention.



***Caution!*** – identifies actions requiring caution.



***Pinch Hazard*** – identifies possible pinch hazards.

## Audience

The *Telequip Transact 2+ User's Guide* is intended for managers and supervisors of businesses that use the Telequip Transact 2+ Coin Dispenser. It describes features of the unit, discusses how to perform standard operations, and how to perform troubleshooting procedures to solve common problems.

## Hazardous Voltages



**Warning:** *There are potentially lethal voltages present inside the coin dispenser whenever it is plugged in. Only a qualified service technician should remove the front or rear covers to access internal components.*

## Heavy Objects



**Caution:** *The Transact 2+ Coin Dispenser weighs about 20 pounds including the coin canister. When transporting the unit, avoid bumping or dropping it, because it can be damaged. Also, if dropped on a body part, the coin dispenser can cause serious personal injury.*



**Caution:** *A canister that is full of coins is quite heavy. Be very careful in handling the canister to avoid damage to the canister or to an individual. Always store the canister flat on its back or in a vertical position on its base on a smooth, flat surface.*

# Preface

Thank you for purchasing the Transact 2+ Coin Dispenser. Using a coin dispenser can save between five and seven seconds on each cash transaction. Saving time translates directly into increased sales, especially during peak business periods. And, with a coin dispenser, your employees will have more time to pay attention to your customers rather than counting out change. Using a coin dispenser provides greater accuracy and fewer cash discrepancies.

# General Information

## Introduction

The Transact 2+ Coin Dispenser (dual-voltage model) is a versatile, heavy duty product that is engineered to provide years of trouble-free operation. Supermarkets, convenience stores, quick serve restaurants, cafeterias, banks, and casinos that use coin dispensers have seen improved customer throughput, increased cashier productivity, and greater customer satisfaction.

Telequip also provides customized coin dispensing automation technology that can be integrated into kiosk-type solutions. Telequip is the coin dispenser supplier of choice for self-checkout systems that have been installed in top retailing companies.

Using microprocessor-based technology, fault protection circuitry, and few moving parts, the Transact 2+ is a very reliable product. Design improvements to the circuit board have resulted in increased immunity to electrical interference and a higher tolerance for incoming “dirty power” environments. The Transact 2+ Coin Dispenser has received a CE marking, a stringent European certification that pertains to safety and environmental standards.

The Transact 2+ uses an RS-232 communications interface, making it easy to integrate into environments using cash registers and point of sale (POS) devices as well as into kiosk-type systems.

PC-based software allows you to easily configure options, set customized features, and run diagnostic tests that were previously available only through hardware upgrades or manually setting switches on the circuit board.

## **International Features**

The Transact 2+ Coin Dispenser (dual-voltage model) has received CE marking and is approved for distribution in the European market. Design features include:

- n Voltage-selectable to operate from either 110 or 220 volts AC, 50 or 60 Hz
- n Detachable power cord that can be ordered with different connectors to match the local power source
- n Several coin canister models that hold different coins including Euro denominations

## **Related Documentation**

The *Telequip Transact 2+ Service Guide* is available for service technicians who work with the Telequip Transact 2+ Coin Dispenser. It describes how to run diagnostic tests, change the default settings for pre-programmed functions, perform advanced troubleshooting procedures, and replace various components and subassemblies.

## **Warranty Coverage and Service**

Telequip warrants that the Transact 2+ Coin Dispenser, if properly installed and used, will be free from defects in material and workmanship for one (1) year following the date of shipment by Telequip.

An Extended Warranty is available for the Transact 2+ CE. This warranty is available for two additional years (3 total years). For specific information on this extended warranty, please visit [www.telequip.com](http://www.telequip.com) and click on “Warranty” or contact your sales representative at Telequip.

If the Transact 2+ Coin Dispenser fails to conform to the above express warranty, Telequip's sole and exclusive liability will be to repair the coin dispenser that fails during the applicable warranty period, provided that:

- n You promptly notify Telequip (603-685-6999) that the Transact 2+ Dispenser is defective and provide a description of the deficiency.
- n You return the Transact 2+ Coin Dispenser to Telequip's facility at your risk and expense.
- n Telequip is satisfied that the claimed deficiency exists and was not caused by accident, misuse, neglect, alteration, improper installation, improper testing or repair. If the returned Transact 2+ Coin Dispenser is defective, transportation charges for the return of the repaired unit to the customer will be borne by Telequip.

## **Technical Support 24/7**

To obtain technical support, you can contact Telequip by telephone, fax or e-mail. The telephones are staffed 24 hours a day, 7 days a week. Please call 603-685-6999 Ext. 131. Fax your questions to us at 603-685-6997 or send e-mail to [service@telequipcorp.com](mailto:service@telequipcorp.com). Our technical support team will get the information you need as quickly as possible.

## **Factory Service**

### **How to Obtain Service**

Your Transact 2+ Coin Dispenser is a rugged and reliable piece of equipment that was designed to provide years of trouble-free operation. In the event your Transact 2+ requires service, however, please contact Telequip Corporation to receive a Return Material Authorization (RMA) number. Please call us during our normal business hours (Monday through Friday, 8:00 a.m. – 5:00 p.m., Eastern Time), at 603-685-6999.

When you call, please have the following information ready:

- n The coin dispenser's serial number, which is printed on a silver label located on the bottom of the unit
- n The type Point of Sale (POS) device or teller system used with the unit
- n A description of the problem

## **Packing the Coin Dispenser for Shipping**

Before packing the coin dispenser, remove the coin cup and the canister. Pack the coin dispenser, canister, and communications cable in a sturdy container, with sufficient packing material to prevent them from being damaged.

## **Shipping Charges**

You are responsible for the shipping charges and risk for returning the coin dispenser. Telequip suggests that you use a shipping service that provides tracking information, and that you insure the equipment for its full value.

## **Repair Charges**

If Telequip is satisfied that the claimed deficiency exists, and your Transact 2+ Coin Dispenser is within the specified warranty period, Telequip's sole and exclusive liability is to repair it. Units repaired under warranty are returned to the customer at Telequip's expense. Abuse, neglect, alteration, improper installation, or improper testing and repair of the unit will void the warranty.

For Telequip coin dispensers that are out of warranty, repairs are completed at a flat charge, plus the cost of parts and shipping.

# Getting to Know the Transact 2+

The following drawings identify the major parts of the Transact 2+ Coin Dispenser.

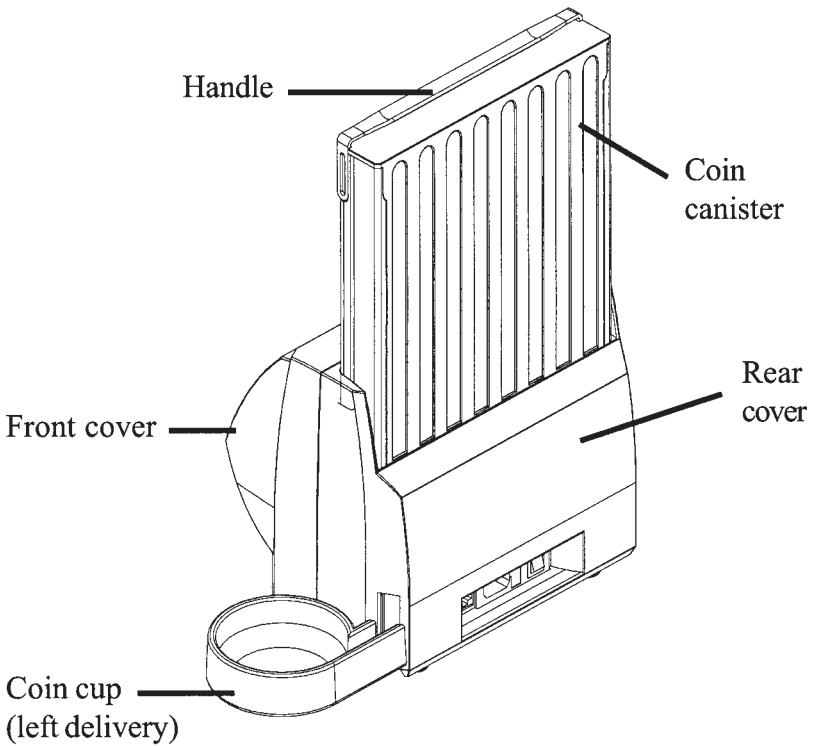

**Coin cup** – Holds dispensed coins. Coin cups can be easily changed to support left or right delivery. Refer to “Installing the Coin Dispenser” on page 12 for instructions for installing the coin cup.

**Left/Right coin delivery** – Coins can be dispensed either from the left side or the right side. For reference, the right side of the coin dispenser is the side on which the Lock assembly is mounted.

**Rear cover** – Encloses the rear of the chassis, and typically faces the cashier.

**Front cover** – The cover on which the Telequip logo appears, and that typically faces the customer. The front cover provides access to various mechanical and electrical assemblies. Because potentially lethal voltages are present inside the chassis when the coin dispenser is plugged in, only an authorized service technician should remove it.

**Coin canister** – Contains the coin inventory. Coin canisters are available in models that support several types of coins. Refer to “Specifications” on page 24 for more information. The coin canister includes a see-through, removable cover.

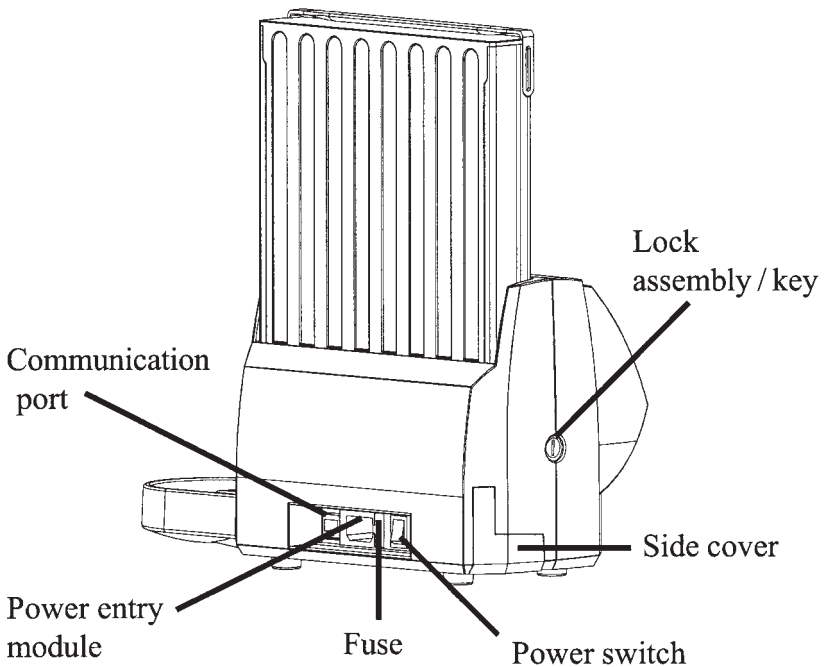

**Communication port** – The serial interface which connects to the point of sale device or terminal.

**Power entry module** – Receptacle into which the power cable is inserted.

**Fuse** – Helps to protect circuitry from damage.

**Power switch** – Powers the coin dispenser on and off.

**Side cover** – Covers the opening to the coin exit ramp. The side cover is removed when you mount a coin cup.

**Lock assembly/key** – Secures the coin canister to the chassis, preventing it from being removed. The key is universal to other Transact 2+ Coin Dispenser locks. Custom locks are available at additional charge. The lock is for security only, and is not required for operation.

## Installation

### Before You Begin

Before you install the Transact 2+, check the area where it will be located, keeping the following points in mind:

- n Typically, the coin dispenser should be installed so that the front cover (with logo) is facing the customer and the rear is facing the cashier.
- n The coin cup should be installed on the side where it is readily accessible to either the customer or the cashier, depending on your operational preference.
- n The mounting surface should be flat, stable, and free of liquids and moisture.
- n The coin dispenser should not be installed where there are vapors or condensation, and where it might be accidentally splashed or sprayed with liquids. Liquids can create a shock hazard and will cause damage to the internal components of the unit, voiding the warranty.



## Factory Settings

The Transact 2+ is configured at the factory according to a customer's specific requests. The following standard options are programmed, unless otherwise specified:

- n “Even depletion” of coins (versus “minimum dispense”)
- n US standard coin canister
- n 9600 baud rate

The procedures to change these options are described in the *Telequip Transact 2+ Service Guide*. Contact your service provider for assistance.

## Installing the Coin Dispenser

To install the coin dispenser, perform the following steps:

1. Set the coin dispenser on a flat, stable surface.
2. Position the coin cup over the exit ramp, and attach the tab to the underside of the chassis with the phillips-head screw provided.

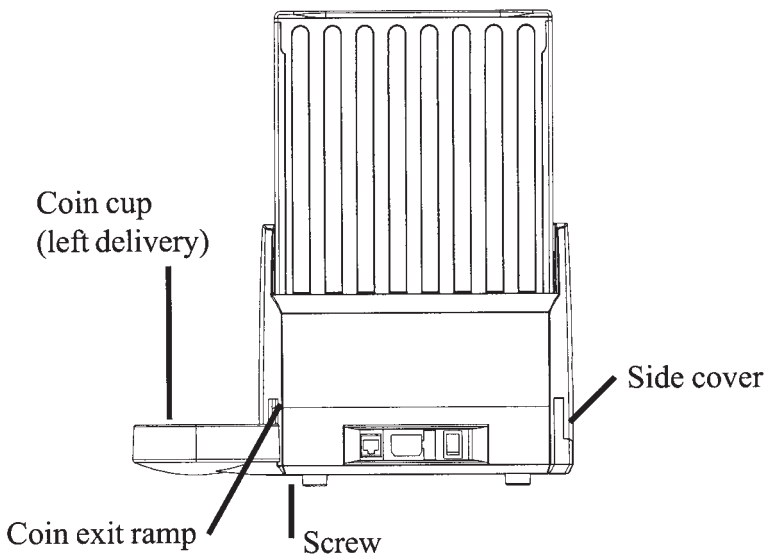

3. Place the coin dispenser on a flat, clear surface in the location where it will be used.
4. Plug the RJ-45 connector on the communications cable, labeled “Coin Disp”, into the communications port.
5. Attach the other end of the communications cable to the POS/teller system.
6. Plug the power cable into the power entry module receptacle.
7. Insert a filled coin canister into the coin dispenser, seating it firmly into place. Fill the canister to at least one third capacity to in order to test it during the installation.

If the level of any coin column drops below the bottom of the calibration strips, the low-coin alarm sounds.

8. Plug the power cable into a suitable power source.
9. Press the power switch to the On position. The coin dispenser is ready to use.

If you have problems, recheck the communications cable connections. If the coin dispenser still does not operate correctly, contact your service provider.

## Changing the Coin Cup

To change the side from which the coin dispenser ejects coins, perform the following steps.

*Note:* As a point of reference, the right side of the coin dispenser is the side on which the lock assembly appears.

To switch the side from which the unit dispenses coins, perform the following steps:

1. Unplug the power cable.
2. Disconnect the communications cable.



3. Remove the original coin cup *and* the original side cover.
4. In the opening over which the original cup was attached, locate the end of the coin ramp, and lift it up so that the ramp tilts towards the opposite direction. Slide the new side cover into the opening, ensuring that it locks the end of the coin ramp in the correct position.
5. Secure the side cover with the Phillips-head screw.
6. On the opposite side of the coin dispenser, install the new cup. Ensure that the cup is properly aligned with the dispenser, and then secure the cup to the bottom of the chassis using the Phillips-head screw.

## Employee Training

To integrate the Transact 2+ Coin Dispenser smoothly into your operation, consider an employee training class. This will help employees become familiar with the coin dispenser and give them the opportunity to ask questions. Topics you should cover are:

- n Pointing out the coin dispenser's features (refer to "Getting to Know the Transact 2+" on page 9)
- n Emphasizing that the covers to the unit should never be removed, because potentially lethal voltages are present within the chassis
- n Advising caution in removing and handling the coin canister, which can be quite heavy
- n Demonstrating the different methods to fill the coin canister (a video on filling the canister is available on request from Telequip)
- n Describing what to do if the low coin alarm sounds (see "Low Coin Alarm" on page 16)
- n Going over troubleshooting procedures (see the Quick Reference Card)

# Coin Dispenser Features

## Dispensing Coins

The Transact 2+ Coin Dispenser dispenses change for a transaction, saving time and ensuring accuracy. The unit can be adjusted to eject coins from either the left or right side by changing the coin cup. Refer to “Changing the Coin Cup” on page 13.

## Even Depletion and Minimum Dispense

To maximize the number of transactions that can be completed before refilling the coin canister, the Transact 2+ Coin Dispenser is set to dispense coins using the even depletion method. This method occasionally substitutes coins (for example, instead of a quarter, 2 dimes and one nickel are dispensed) so that the entire coin inventory is depleted more evenly. In practice, even depletion offers an additional 30 to 70 transactions between canister fills.

The minimum dispense method ejects the minimum number of coins possible per transaction (for example, to return 50 cents, two quarters are dispensed).

Your service technician can set your coin dispenser for either option with the Test and Configure Application, as described in the *Transact 2+ Service Guide*.

## Coin Capacity

The Transact 2+ US Standard coin canister holds more than \$110 in coins, distributed between eight columns. There are two quarter, two dime, one nickel and three penny columns. Each column holds up to three rolls of coins.

The high capacity of the Transact 2+ coin canister assures more transactions between refills. A single US Standard canister can last between 2-3 hours in a high volume sales setting.

The time between fills will vary, depending on your particular environment. You can perform your own calculations by using the following information:

- n Assume an average transaction dispenses 50 cents
- n Divide the amount of the coin inventory (in this example, a US Standard coin canister with over \$100 in coins) by 50 cents, which yields over 200 transactions per canister
- n Determine how many transactions per hour are conducted in your operation (for this example, we use 70 transactions)
- n Divide the 200 transactions per filled canister by 70 transactions per hour, which yields 2.7 hours per canister

This example assumes the even depletion option, which is the factory-standard setting.

## **Low Coin Alarm**

When any column of coins in the canister drops below a certain level, the low coin alarm will sound. After the alarm sounds, three more dispenses are allowed before the machine stops dispensing coins. To silence the alarm, turn the power switch off. Refill the coin dispenser or remove the depleted canister and replace it with a filled one, and then turn the power back on.

## **Lock Assembly**

The Transact 2+ Coin Dispenser includes a lock assembly that secures the coin canister in place. The key is universal and can be used with any Transact 2+ Coin Dispenser. Custom locks are available from Telequip for an additional charge. The lock is for security only, and is not required for operation.

## **Power Cable**

The cable that connects the coin dispenser to the source of electrical power is detachable, and available in several terminations to match local power receptacles. Contact Telequip Corporation for more information.

## Communications Cable

A standard RS-232 serial cable is used to connect the Transact 2+ Coin Dispenser to the point of sale (POS) device or teller system. The cable end that plugs in to the coin dispenser is terminated with an RJ-45 connector.

The other end of the cable is typically fitted with a DB-9 female connector, however, other connectors may be requested when placing an order.

## Operation

This section describes operations such as powering the coin dispenser on, loading the coin canister, reading how much currency is in a coin canister, and cash management procedures.



**Warning:** *Do not remove the covers to the coin dispenser because there are potentially lethal voltages inside. There are no user serviceable components inside the chassis.*

### Filling the Coin Canister



Before you remove the coin canister, press the power switch to the Off position. If the coin dispenser is switched on when the coin canister is removed, one of the solenoids may fire, causing a pinch hazard.

Filling a coin canister by hand takes approximately five minutes, but may take longer in the beginning. You can use either rolled or loose coins to fill the canister. Knowing the value of the rolled coins you add makes it easier to count the total value of coins when the canister is filled.

Telequip has developed a manual device, the "Transact CLS", to help enable the rapid loading of coin into the canisters. The loading mechanism allows for a smooth, speedy fill of the individual columns of coins.

Recognizing that time is money, the mechanism dramatically reduces the time required to load each canister. This optional equipment is available from Telequip. Call your sales representative for pricing and availability information. See pages 32-33 for CLS loading instructions.

Perform the following steps to load the canister using loose coin, or refer to the EZ fill method on the quick reference card for using rolled coin:

1. Remove the canister from the base.
2. Set the canister on a flat, stable surface, and fold the carrying handle underneath, providing a good load angle.
3. Remove the canister cover by compressing the two thumb points at the bottom of the canister and sliding the cover up and off.
4. Take a comfortable amount of coins between your thumb and first finger.
5. Place the column of coins over the top of the column, and then let it slide down into the column. Repeat this process until the canister is filled to the desired starting level.
6. Place the cover back on the canister.

## **Reading the Calibration Strips**

The calibration strips at the back of the coin columns are used to determine the approximate value of the coins in each column. Due to variations in coin thickness and how the coin rims align when they are stacked, the values indicated by the calibration strips may be off a small amount – one or 2 coins at most.

The correct way to use the calibration strips is to read the first fully visible number that appears above a column of coins.

## **Additional Canisters**

Many businesses purchase extra coin canisters to improve efficiency. A filled canister can be quickly swapped with a depleted canister with minimal impact to the operation.

Several models of coin canisters are available that hold coins used by the United States, Canada, and several European countries. Refer to “Parts List” on page 23 for details.

## Cash Management Procedures

Some customers find that using a coin dispenser improves their cash management practices. By filling the coin canister to a fixed level, and keeping it assigned to the safe balance for accounting purposes, you can minimize the counting and handling of coins.

The following procedure describes one method to manage your cash balances:

1. Decide the value of coins that you want to assign to the canister and then fill it with that amount (for example, \$100 US).
2. Using an indelible pen, mark the canister extrusion to indicate the level of coins in each column.
3. At the start of the shift, issue the cashier a drawer with a predetermined amount of bills (for example, \$80 US) and then lock a filled coin canister into the dispenser.

As sales are rung up, the total value of bills in the drawer increases by the amount of the sales *plus* the value of coins dispensed. This is because the coins are part of the safe balance instead of the drawer balance.

4. Periodically inventory and remove excess bills from the register as you normally would. Also, any coins received during transactions may be added to the coin canister.
5. When the shift is over, take a sales reading, and remove the cash drawer from the register. Add any coins from the drawer to the coin canister (but not above the marked refill level), and then remove the coin canister from the dispenser.
6. Using the calibration strips, count the value of coins remaining in the canister (for example, \$60 US) and subtract the total from the amount initially loaded into the canister (\$100 US). This yields the value of coins dispensed (\$40 US in this example).

7. Calculate the total sales rung in during the shift. The sales total should equal the combined value of bills received and the coins dispensed.

For example, if sales totaled \$800 US, and \$40 US in coins was dispensed, the cash drawer should contain \$920 US. That is, the starting balance in the drawer, plus the bills taken in from sales, plus the amount of coins dispensed.

Be sure to allow for a slight cash variance due to coin rim thickness and stacking. If each column in a US Standard canister is off by one or two coins, the total value of coins in the canister, as indicated by the calibration strips, can vary up to \$1.56 US.

## Maintenance

The Transact 2+ Coin Dispenser is designed to be low maintenance. The canister should be handled with care and not dropped. Always store the canister flat on its back or in a vertical position on its base on a smooth flat surface.

It is important to keep the coin dispenser and the canister clean. Use only a soft, damp cloth to remove surface dirt.



The unit does NOT need to be oiled. Using oil, detergents or petroleum-based cleaning compounds can adversely affect the reliability of the coin dispenser.

# Troubleshooting

This section describes some common problems and the actions you can take to correct them. If you cannot correct a problem, contact your service technician and describe the problem.

## **Problem: The wrong change is being dispensed**

### **Actions:**

1. If the coin dispenser is programmed for even depletion, the denominations of the coins dispensed may be different from what you expect. For example, if the change due is 25 cents (US), two dimes and a nickel may be dispensed instead of a quarter. This behavior is not a malfunction.
2. Make sure the coin canister is firmly seated.
3. Check for, and remove, any bent coins in the canister.
4. Carefully examine the canister for damage. If the canister is damaged, order a replacement from Telequip.
5. Check for spills or foreign matter in the coin canister. If necessary, clean the canister with a soft, damp cloth.
6. Check for foreign matter in the exit ramp located above the coin cup. Use an unsharpened pencil to dislodge and remove any blockage in the coin ramp.
7. Verify correct coin denomination in each column.

## **Problem: Coins are jamming and not ejecting correctly**

### **Actions:**

1. Make sure the coin canister is firmly seated.
2. Check for, and remove, any bent coins in the canister.
3. Carefully examine the canister for damage. If the canister is damaged, order a replacement from Telequip.

4. Check for spills or foreign matter in the coin canister. If necessary, clean the canister with a soft, damp cloth.
5. Check for foreign matter in the exit ramp located above the coin cup. Use an unsharpened pencil to dislodge and remove any blockage in the coin ramp.

**Problem: Power is on, change does not dispense, and it appears there is no communication with the POS/teller system**

**Actions:**

1. Check both ends of the communication cable and ensure they are securely connected to the coin dispenser and the POS/teller system, respectively.
2. Check to see if there are any deep nicks, or cuts on the cable. If so, contact your service technician, who can test the cable and determine if it needs to be replaced.

**Problem: Coin dispenser will not turn on**

**Actions:**

1. Make sure the power switch is in the On position.
2. Check to see that the power cable is securely plugged into a live power source.
3. Using a flat-blade screwdriver, remove the fuse assembly from the chassis.
4. Replace the fuse with a standard 1.6 amp, 20mm, 250 Volt, Slo-Blo fuse, available in many stores that sell electronic parts.



DO NOT use a fuse rated for a higher amperage.

# Parts List

## **Bowl Coin Cup and Side Cover**

	<b>Part number</b>
Left, grey	310-381L and 310-364G
Right, grey	310-381R and 310-365G
Left, charcoal	310-381L and 310-364C
Right, charcoal	310-381R and 310-365C

## **Coin Canister**

US Standard	340-464
US High Capacity	340-441
US Golden Dollar	340-406
Canadian	340-405
United Kingdom	340-404
Euro	340-450

*Contact Telequip Corporation for information about coin canisters for other countries.*

## **Calibration Strips**

Available for the coin canisters listed above

## **Also Available:**

US Coin Canister Cover 310-471

*Compatible with US Standard Canister (340-464) only*

Universal Canister Cover 310-384

*Contact Telequip Corporation for information about covers for other coin canisters.*

Interface Cable	varies by type
Mounting Spacers	330-036 (Brass)
Mounting Kit	340-463 (Hardware Included)
Replacement Keys	340-314S
CLS (US)	340-517

# Specifications

*Note: Specifications and design features are subject to change without notice.*

**Size:** 9-3/4" W x 6-1/2" D x 14-1/2" H – with canister  
9-3/4" W x 6-1/2" D x 7-3/4" H – without canister

**Weight:** 13.9 lbs. – canister  
9.8 lbs. – without canister

**Power:** Dual-voltage model – Switch-selectable,  
110 VAC or 220 VAC, 50 or 60 Hz

## Power

**Consumption:** 100W

**Power Cord:** Detachable power cords with different terminations to match local power receptacles, and in different lengths, are available.

## Communication

**Cable:** Cables with various serial cable terminations and in different lengths are available.

**Fuse:** 1.6 Ampere, 20mm, 250 volt, Slo-Blo

**Certifications:** CE, UL, CUL, FCC

## Maximum

<b>Capacity:</b> US Standard	\$111.42
US High Capacity	\$128.91
US Dollar	\$316.48
Canadian	\$483.44
United Kingdom	£361.20
Euro	398.16 Euro

# Transact 2+ Troubleshoot Flowchart

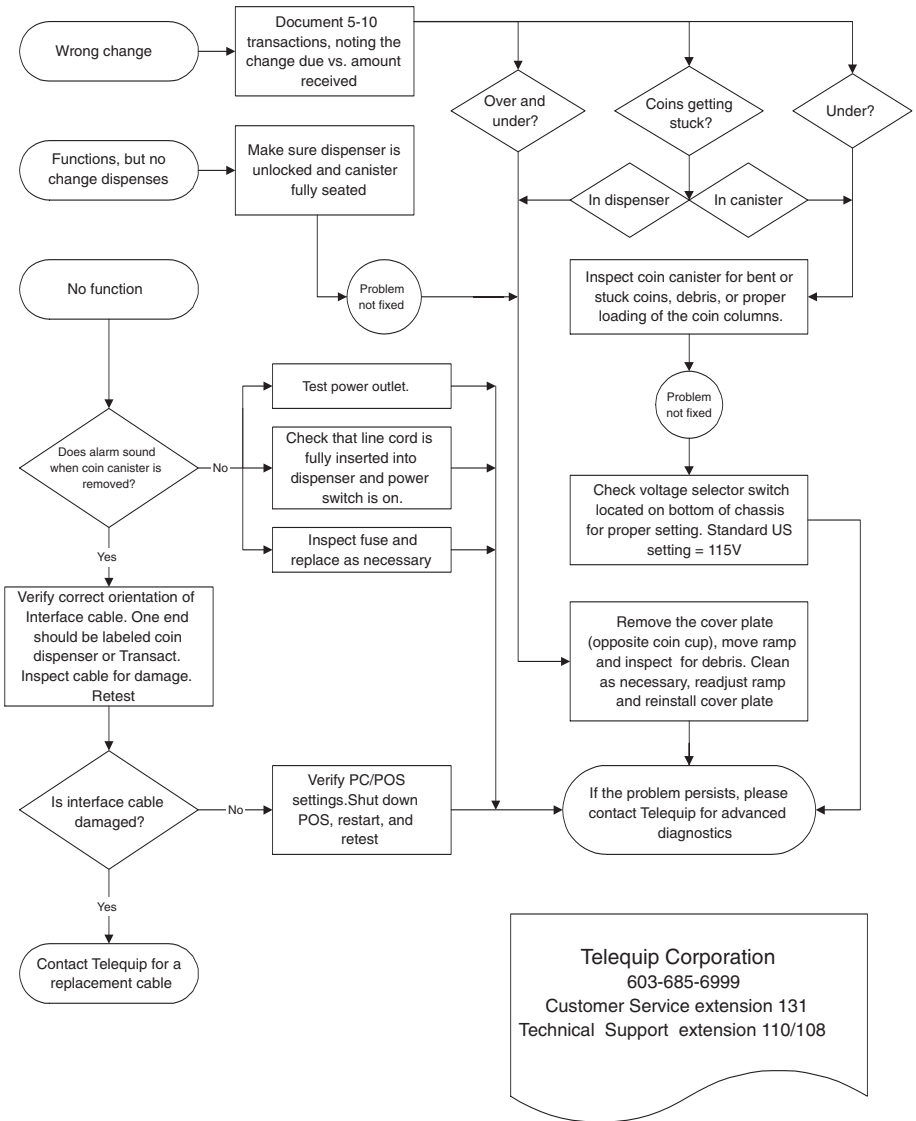

## ATTACHING THE OPTIONAL MOUNT BRACKET #340-463 (NOT INCLUDED)

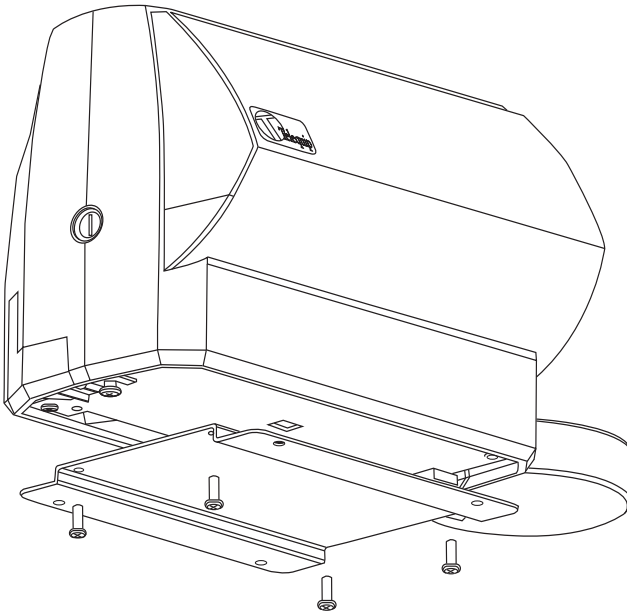

1. Remove and discard rubber feet from bottom of coin dispenser while retaining the four screws.
2. Position mount bracket underneath coin dispenser and secure with the four screws from the previous step.

## SURFACE MOUNTING PROCEDURE FOR TRANSACT 2+ COIN DISPENSER

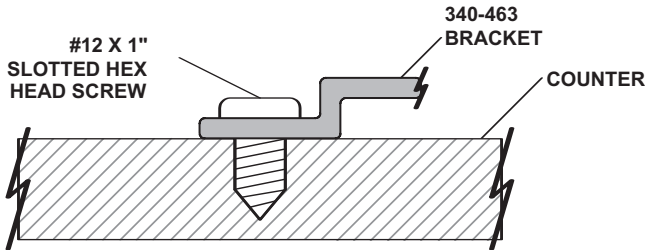

1. Use a pen or marker to transfer hole locations from the mounting bracket to the counter top.
2. Drill pilot holes into the counter for #12 x 1" slotted hex head screws, using a 1/8th inch drill bit.
3. Mount dispenser/bracket to counter using hex head screws.

## THROUGH COUNTER MOUNTING PROCEDURE FOR TRANSACT 2+ COIN DISPENSER

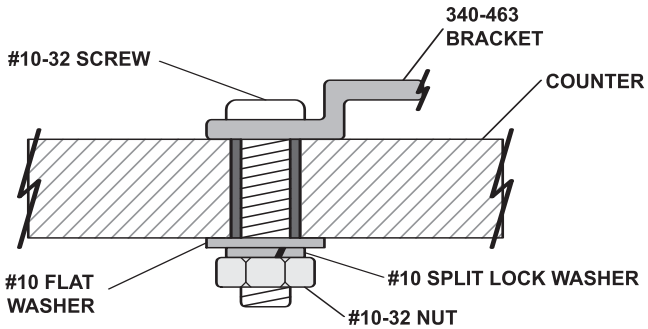

1. Use a pen or marker to transfer hole locations from the mounting bracket to the counter top.
2. Drill clearance holes through the counter for #10-32 mounting hardware using  $7/32"$  (#3) drill bit.
3. Mount dispenser/bracket to counter, as shown in diagram.

## SINGLE BOLT MOUNTING PROCEDURE FOR TRANSACT 2+ COIN DISPENSER

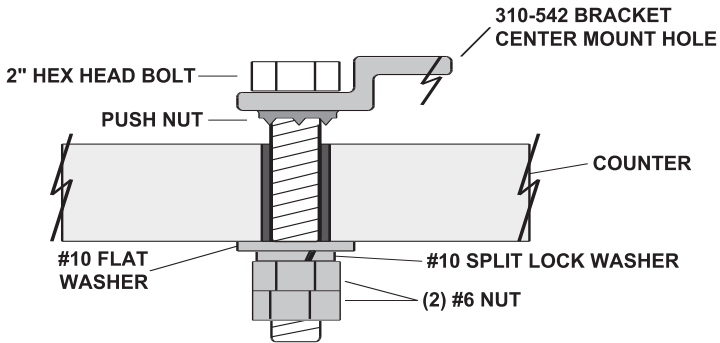

1. Use a pen or marker to transfer center hole location from the mounting template to the counter top.
  2. Drill clearance hole through the counter for supplied hex mounting bolt using a 9/32" drill bit.
  3. Slide the hex bolt head into the receiver on the bracket. Secure by sliding push nut down length of bolt while pulling bolt head tight to bracket.
- 
1. Position coin dispenser on counter top with mount bolt thru the drilled 9/32" clearance hole. From below counter top, add flat washer then split lock washer. Secure the washers with (1) #6 nut and tighten with a wrench.
  2. Add 2nd #6 nut. Lock nuts together by tightening the 2nd #6 nut against the first nut (Swage) with a wrench.

## MOUNTING PROCEDURE FOR TRANSACTION 2+ COIN DISPENSER

- n First determine the type of mounting method, which fits your needs.
  - ▶ The mounting bracket is not required when installing on a flat countertop with the coin cup over hanging the left edge.
  - ▶ In all other applications the mounting bracket is required.

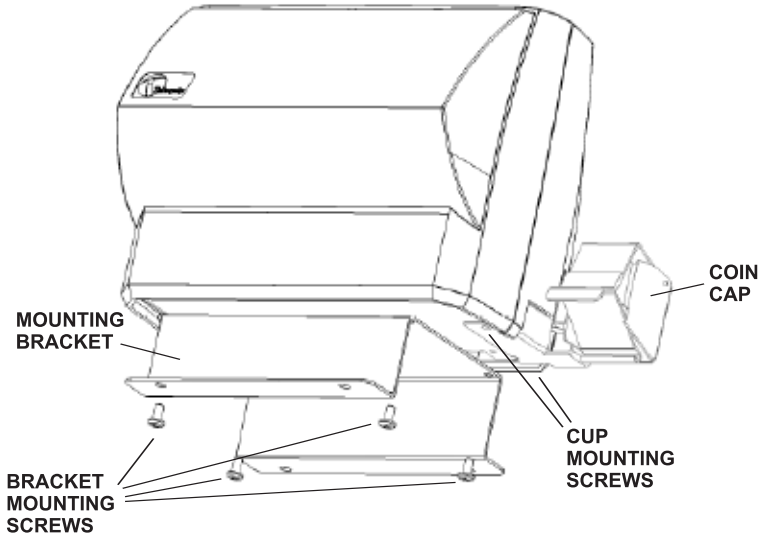

1. To mount the cup, remove the two existing cup-mounting screws, position the cup and attach with the same mounting screws.
2. Refer to page 26 of the *Telequip Transaction 2+ User's Guide* for installation of the mounting bracket.
3. With steps 1 and 2 completed, you can then mount the coin dispenser to the counter. Refer to pages 27 & 28 of the *Telequip Transaction 2+ User's Guide*. When mounting to a wire rack, use plastic ty-wraps (not supplied) to secure the coin dispenser.

*Transaction 2+ User's Guide* is available online at [www.telequip.com](http://www.telequip.com)

## MOUNTING SPACER PROCEDURE FOR TRANSACT 2+ COIN DISPENSER

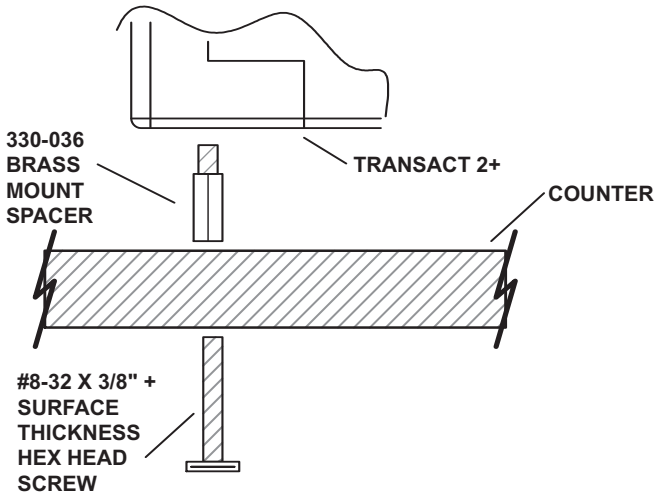

1. Use a pen or marker to transfer hole locations from the mounting bracket to the counter top.
2. Drill clearance holes through the counter for #10-32 mounting hardware using 7/32" (#3) drill bit.
3. Mount dispenser/bracket to counter, as shown in diagram.

# Telequip COIN DISPENSER

## Canister Loading Solution Instructions

### USA Version

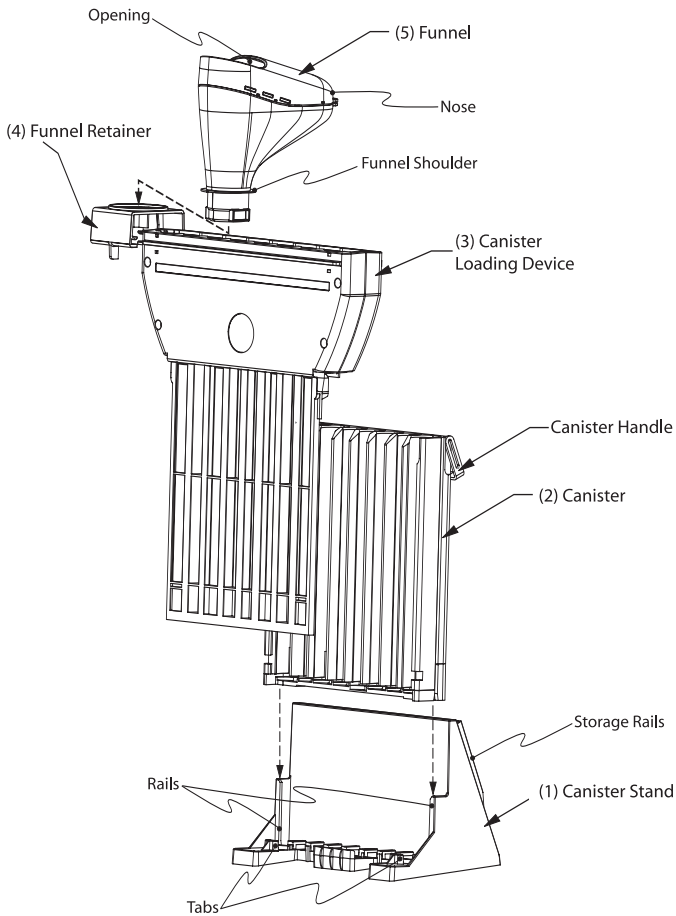

1. Remove the clear plastic canister cover by depressing the two tabs at the bottom and sliding up. The canister handle should hang toward the back of the canister.
2. Set the canister stand (1) on a flat surface. Assemble the canister (2) to the stand by sliding it down onto the two rails.

3. Attach the canister loading device (3) to the canister by lowering the device onto the canister, engaging the top rear of the canister, then pivoting the bottom of the loading device inward to engage the front of the canister. Slide the device down until it engages the tabs at the base of the canister stand.
4. If the funnel retainer (4) is not already assembled onto the loading device, slide it onto the two rails at the top of the loading device. It will only assemble one way. When assembled properly, the funnel retainer will not slide off the loading device.
5. Assemble the funnel (5) to the funnel retainer by dropping the funnel onto the retainer with the slots aligned. Rotate the funnel 1/4 turn clockwise, positioned with the opening in the front and "nose" in the back.
6. To position the funnel over the corresponding denomination, lift the funnel slightly and slide the funnel and retainer until positioned over the appropriate column. Drop the funnel in place. The shoulder of the funnel should be flush with the retainer.
7. Begin loading coins for that denomination by slowly pouring coins into the funnel either by hand, cup or directly from the coin bag. Continue filling until that column is filled to the desired height indicated by the calibration strips on the canister.
8. Repeat this process for each denomination.
9. To remove the loading device, rotate the funnel turn counter-clockwise and pull upward to disengage from the funnel retainer. Slide the loading device upward to disengage from the bottom tabs of the canister stand. Swing the bottom device out and up to completely disengage.
10. Re-assemble the clear plastic cover to the canister. Using the handle, slide the canister upward to remove from the stand. The loading device is stored by sliding it into the storage rails on the back of the stand.

**NOTES:**