

1 Getting Started

Unpack and Get Organized

1. Unpack all the components from the box.
2. Save the packaging.
3. Take inventory and make sure all parts are included:

- A - Coin Dispenser base
- B - Coin canister
- C - 2 Coin cups (a left dispense and a right dispense)
- D - Cables (USB or Serial)
- E - Power Brick & Power Cord
- F - Telequip® User Guide
- G - Keys

4. Obtain coin for loading into canister

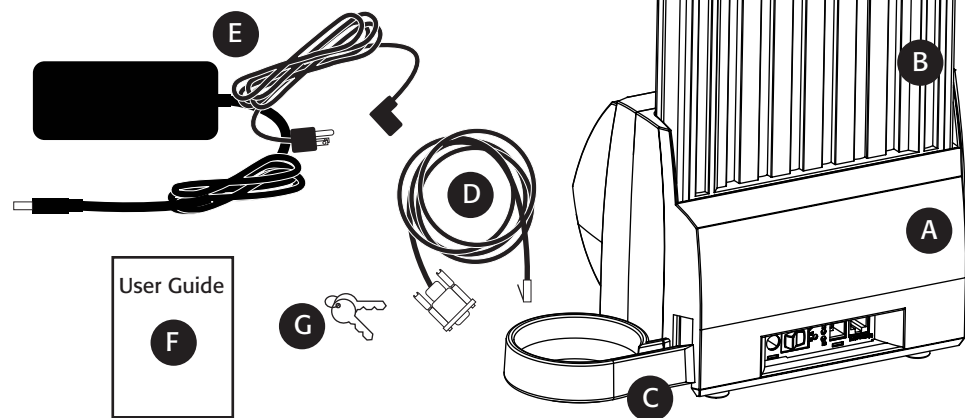

2 Set Up Decisions

Placement of Coin Dispenser and Coin Cup Direction

A few basic set-up decisions need to be made in relation to the placement of the Coin Dispenser and the direction of the coin cup.

1. The Coin Dispenser base is usually placed alongside the POS system with the logo on the front cover facing the customer.
2. Right or Left Coin Exit (For details, consult the T-Flex User Guide)
 - a.) The coin cup should be installed on the side where it is readily accessible to either the customer or the cashier, depending on your operational preference.

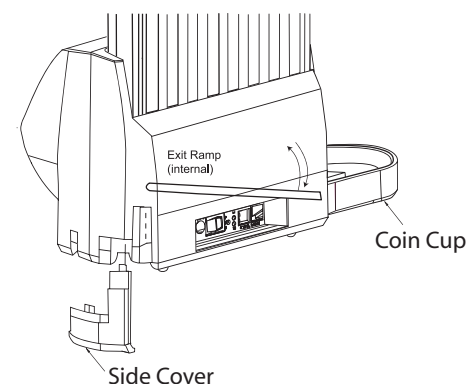

- b.) The Exit Ramp can be positioned to direct coins for either left- or right-side coin cup placement. A Side Cover is placed opposite of the coin cup to hold the exit ramp at the correct position.

3 Assembling the Coin Dispenser

Set Up the Coin Dispenser

1. To attach the coin cup, begin by removing the Phillips screw that is in place. Attach the coin cup to the appropriate side of the Coin Dispenser, align to exit ramp, and attach the cup with the Phillips screw that is provided.

Load the Canister

1. Load coin into the canister:
 - a.) Remove the canister cover. Position handle to back side and place on flat surface in order to fill it with coin.
 - b.) Load coin into canister. Consult the T-Flex User Guide for easy methods.
 - c.) Ensure ALL columns contain coin, and fill to at least one third capacity to test during installation.
 - d.) Place the filled coin canister into the T-Flex Coin Dispenser base, seating it firmly in place.

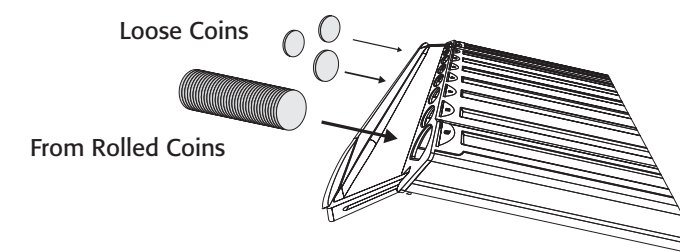

4 Getting Connected

Connect the Coin Dispenser to the Point of Sale System

1. First, plug cables into the Coin Dispenser. Plug the connector on the communications cable into the USB **OR** RS-232 communications port of the Coin Dispenser.
2. Next, connect to the POS system. Attach the other end of the communications cable to the appropriate USB or RS-232 port on the Point of Sale system.

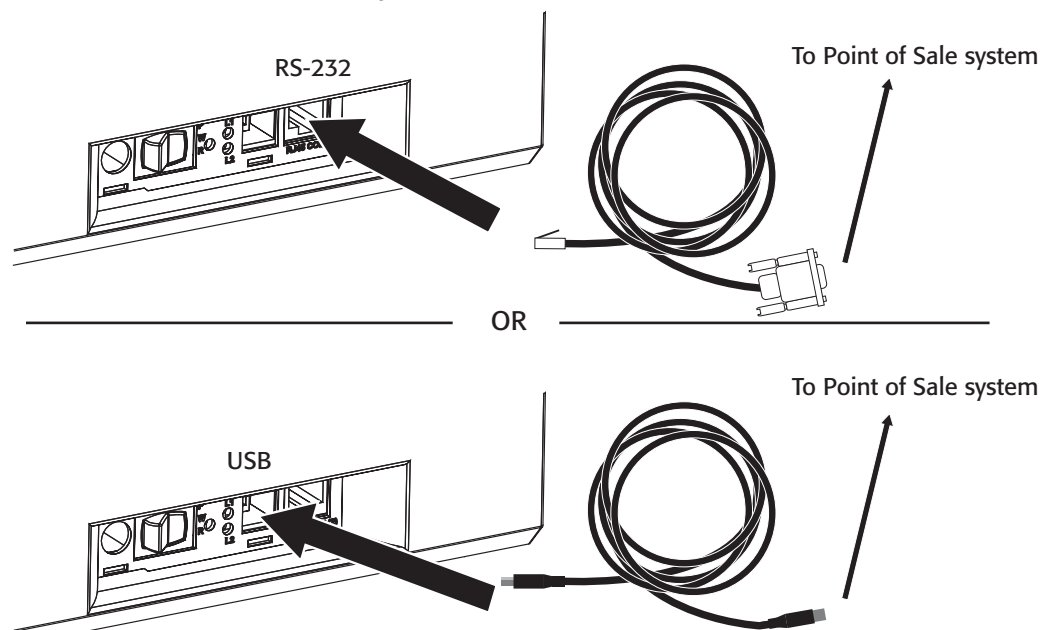

5 Supplying Power

Connect the Coin Dispenser to a Power Source

1. Connect the power cord to the power brick.
2. Plug the cable from the power brick into the Coin Dispenser.
3. Plug the AC power cord into a suitable power outlet.

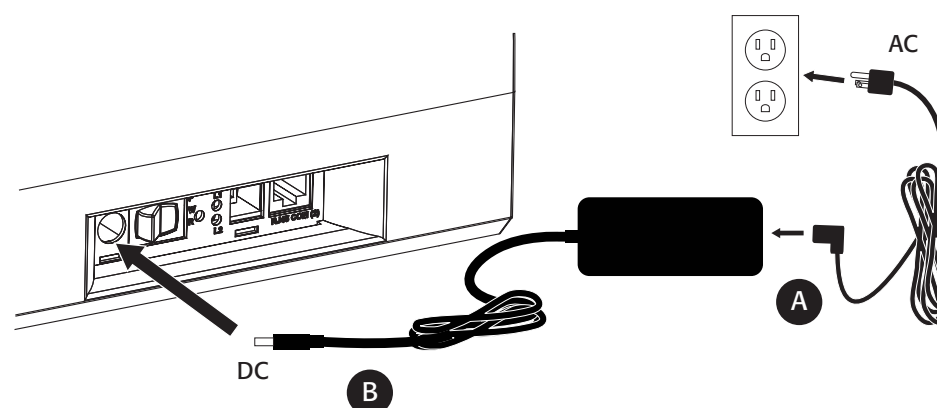

6 Test and Run

Note: To complete the installation, you must enable the T-Flex Coin Dispenser on your register or Point of Sale system. If necessary, contact your IT department or your service provider.

1. Turn on the T-Flex Coin Dispenser.
2. Examine the power brick for a green light (constant) indicating "on and ready".
3. Review the indicator lights on the Coin Dispenser:
 - a.) Green (constant): On & Ready
 - b.) Red (constant): Machine Error (Refer to the Troubleshooting flow chart in the T-Flex User Guide)
 - c.) Red (blinking): Low coin (Remove the canister and re-fill with coin.)
 - d.) Yellow (blinking): Flashes during communications to the host PC
4. Ring up an order and ensure the coin is dispensing correctly.
5. Any issues, refer to the T-Flex User Guide for more detailed instructions.